



MARINE OIL & TRANSMISSION COOLERS

GENERAL OIL , TRANSMISSION & MERCURISER SPECIAL APPLICATIONS



COPPER TUBE ENGINE OIL & TRANSMISSION COOLERS

Replacement transmission oil coolers for use with all transmission models used with gas or diesel marine engines, These coolers may also be used as engine oil coolers, Each cooler is constructed entirely of copper with brass fittings and is designed to stand up to the most rugged marine applications

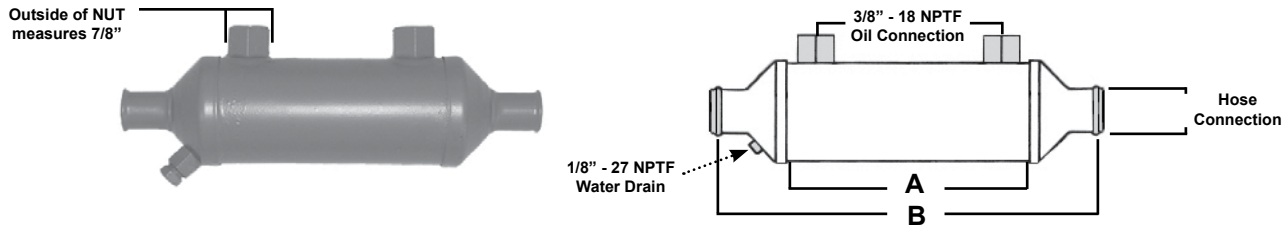

Part#	A - Body Length	B - Overall Length	Hose Connection	Oil Connection
SKP0018	5"	8"	3/4"	3/8", N.P.T.F.
SKP0019	5"	8"	1"	3/8", N.P.T.F.
SKP0020	5"	8"	1-1/4"	3/8", N.P.T.F.
SKP0023	6"	9"	3/4"	3/8", N.P.T.F.
SKP0024	6"	9"	1"	3/8", N.P.T.F.
SKP0025	6"	9"	1-1/4"	3/8", N.P.T.F.
SKP0028	9"	12"	3/4"	3/8", N.P.T.F.
SKP0029	9"	12"	1"	3/8", N.P.T.F.
SKP0030	9"	12"	1-1/4"	3/8", N.P.T.F.
SKP0033	12"	15"	3/4"	3/8", N.P.T.F.
SKP0034	12"	15"	1"	3/8", N.P.T.F.
SKP0035	12"	15"	1-1/4"	3/8", N.P.T.F.



MERCURISER SPECIAL APPLICATION OIL COOLERS

Each cooler is constructed entirely of copper with brass fittings and is designed to stand up to the most rugged marine applications

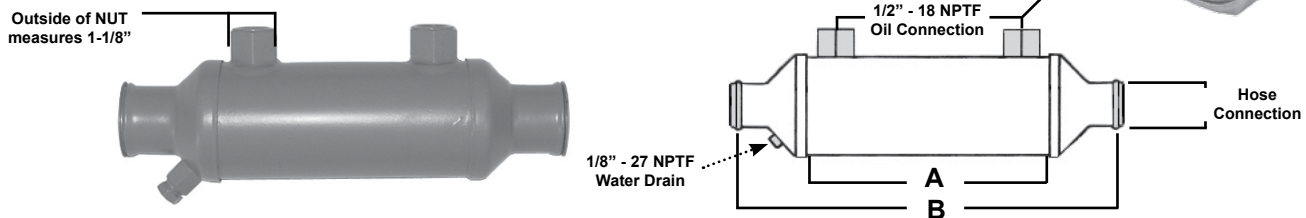

Part#	A - Body Length	B - Overall Length	Hose Connection	Oil Connection
SKP63831A3	5"	8"	1-1/4"	1/2", N.P.T.F.
SKP63832A1	9"	12"	1-1/4"	1/2", N.P.T.F.
SKP63832T	12"	15"	1-1/4"	1/2", N.P.T.F.
SKP806426T	5"	8"	1-1/4"	1/2", **FEMALE FLARE

MARINE OIL & TRANSMISSION COOLERS

MERCUISER OIL & POWER STEERING COOLERS



SEAKAMP

MERCUISER POWER STEERING COOLERS

Each cooler is constructed entirely of copper and is designed to stand up to the most rugged marine applications

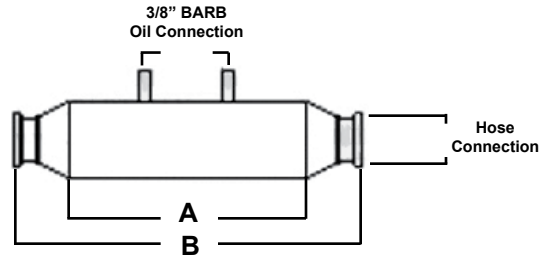
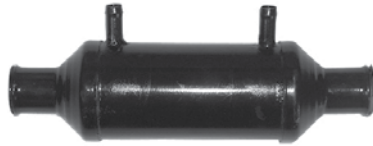

Part#	A - Body Length	B - Overall Length	Hose Connection	Oil Connection
SKP99356A1	5"	8"	1"	3/8" BARB
SKP99356A2	5"	7-1/2"	1-1/4"	3/8" BARB

SEAKAMP

MERCUISER OIL & POWER STEERING COOLERS

Each cooler is constructed entirely of copper and is designed to stand up to the most rugged marine applications

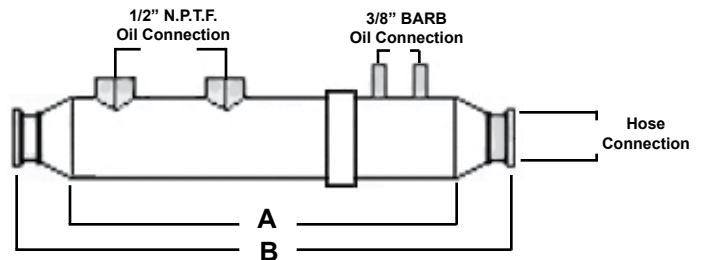
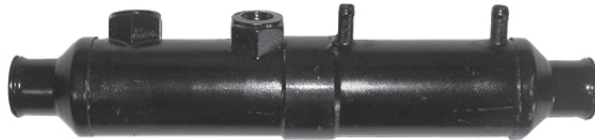

Part#	A - Body Length	B - Overall Length	Hose Connection	Oil Connection
SKP89690T	10"	12-1/2"	1-1/4"	(2) 3/8" BARB / (2) 1/2" N.P.T.F.
SKP85152T	14"	16-1/2"	1-1/4"	(2) 3/8" BARB / (2) 1/2" N.P.T.F.

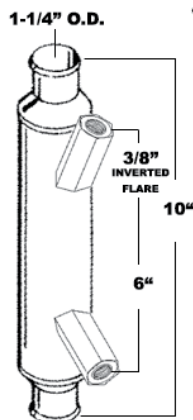

Part#

SKP807371T

Description:

For MCM/MIE GM V8 BB 454 cid (7.4L) / 502 cid (8.2L) Replaces #807371T

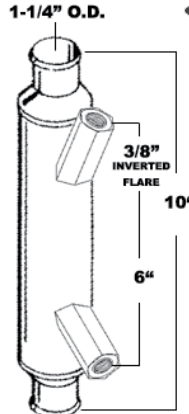

Part#

SKP807371T1

Description:

For MCM/MIE GM V8 BB 454 cid (7.4L) / 502 cid (8.2L) Replaces #807371T1

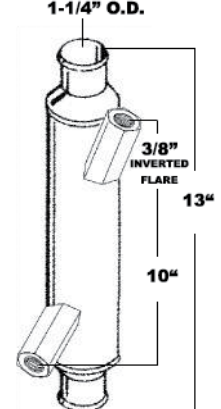

Part#

SKP807372T

Description:

For MCM/MIE GM V8 BB 454 cid (7.4L), 502 cid (8.2L) engines (Gen VI 1996-1998) Replaces #807372T



MARINE OIL & TRNASSMISSION COOLERS

MARINE POWER & OMC POWER STEERING & OIL COOLERS

MARINE POWER OIL & TRANSMISSION COOLERS

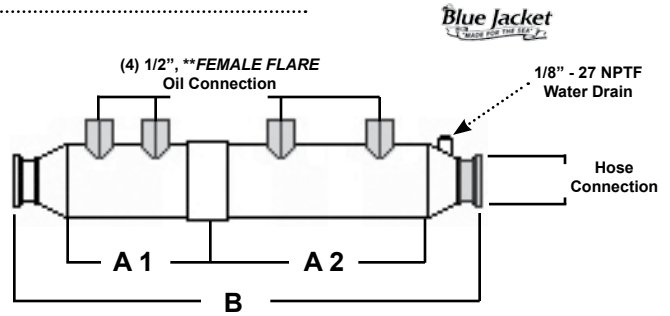
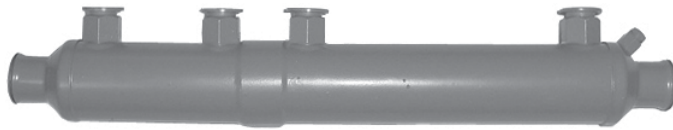

Part#	A - Body Length	B - Overall Length	Hose Connection	Oil Connection
OCLMP001	(A1) 5" -- (A2) 9"	17"	1-1/4"	(4) 1/2", **FEMALE FLARE

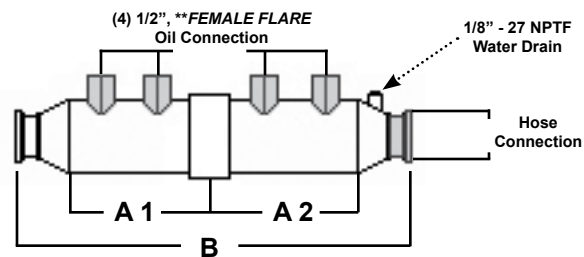

Part#	A - Body Length	B - Overall Length	Hose Connection	Oil Connection
OCLMP002	(A1) 3-1/2" -- (A2) 3-1/2"	13"	1-1/4"	(4) 1/2", **FEMALE FLARE

OMC POWER STEERING COOLERS

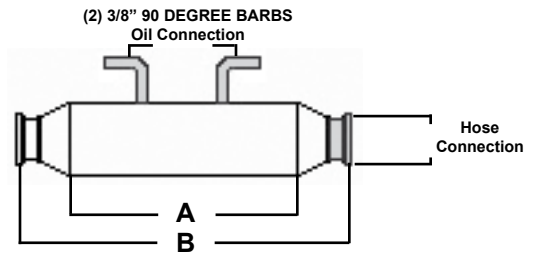
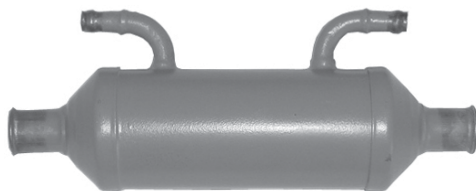

Part#	A - Body Length	B - Overall Length	Hose Connection	Oil Connection
OCL985840	5"	8-1/4"	3/4"	90 DEGREE 3/8" BARB
SKP3851921	5"	8-1/4"	1"	90 DEGREE 3/8" BARB

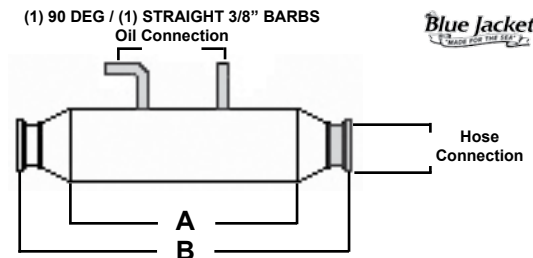

Part#	A - Body Length	B - Overall Length	Hose Connection	Oil Connection
OCL985716	5"	8-1/4"	3/4"	(1) 90 DEG., (1) STRAIGHT 3/8" BARB

MARINE OIL & TRANSMISSION COOLERS

CRUSADER "U" OIL & TRANSMISSION COOLERS



CRUSADER "U" COOLERS

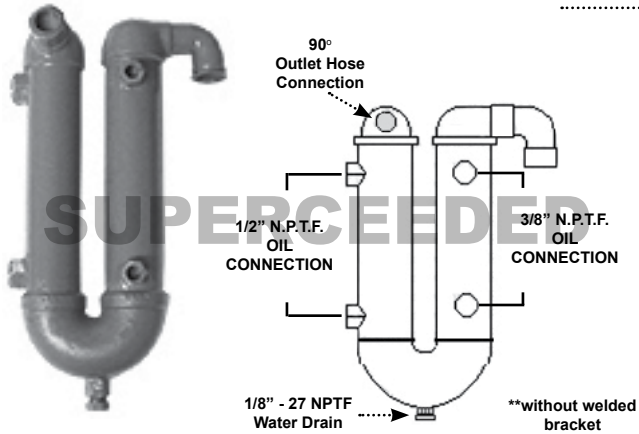

Part#	Hose Conn.	Oil Conn. N.P.T.F.
Superceeds to SKP97464 (below)	1-1/4"	(2) 1/2" / (2) 3/8"

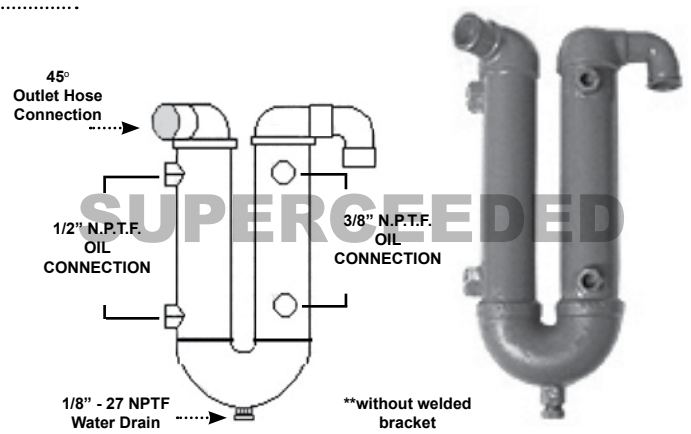

Part#	Hose Conn.	Oil Conn. N.P.T.F.
Superceeds to CRU97878 (below)	1-1/4"	(2) 1/2" / (2) 3/8"

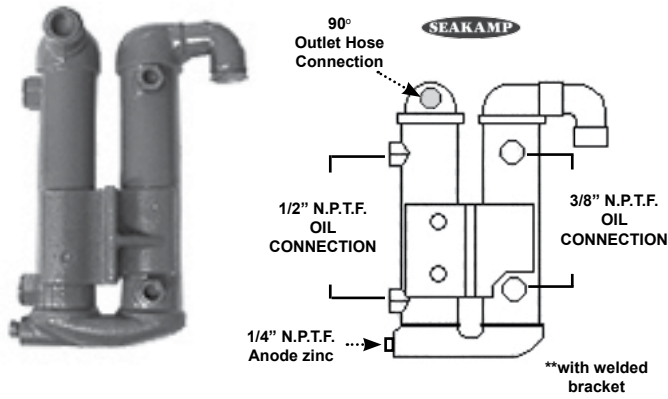

Part#	Hose Conn.	Oil Conn. N.P.T.F.
SKP97464	1-1/4"	(2) 1/2" / (2) 3/8"

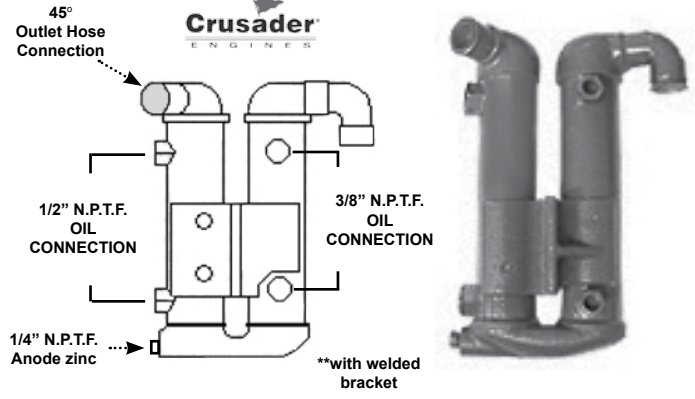

Part#	Hose Conn.	Oil Conn. N.P.T.F.
CRU97878	1-1/4"	(2) 1/2" / (2) 3/8"

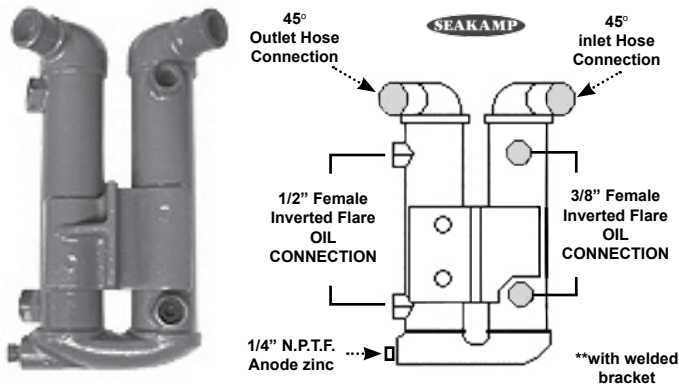

Part#	Hose Conn.	Oil Conn. Female Inverted Flare
SKP98123	1-1/4"	(2) 1/2" / (2) 3/8"

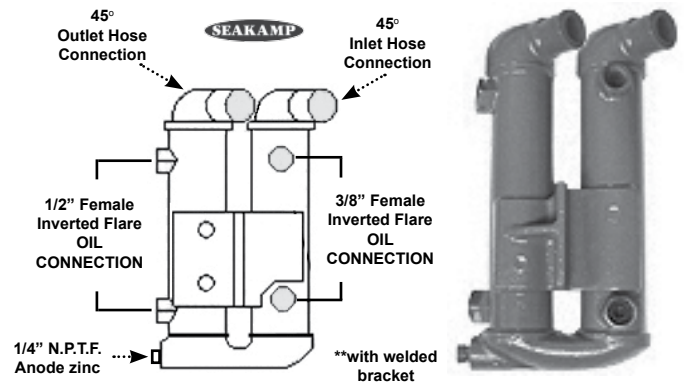

Part#	Hose Conn.	Oil Conn. Female Inverted Flare
SKP98570	1-1/4"	(2) 1/2" / (2) 3/8"



MARINE OIL & TRNASSMISSION COOLERS

CRUSADER "U" COOLERS & MOUNTING BRACKET

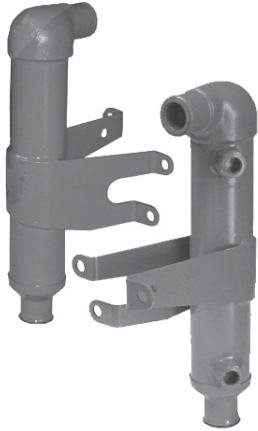

**with welded bracket

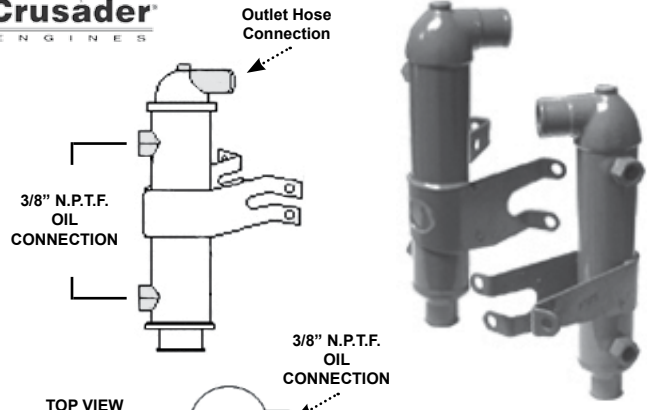
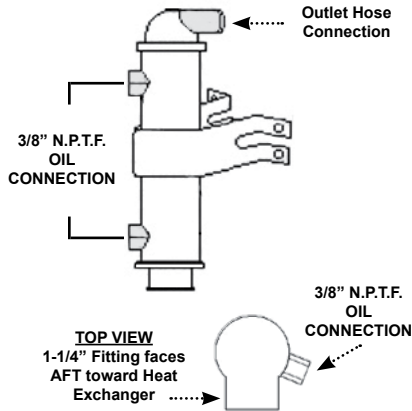

**with welded bracket

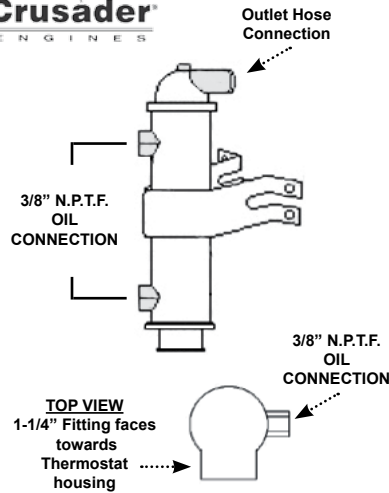

Part#	Hose Conn.	Oil Conn. N.P.T.F.
CRU97885	1-1/4"	(2) 3/8"

Part#	Hose Conn.	Oil Conn. N.P.T.F.
CRU97886	1-1/4"	(2) 3/8"



**without welded bracket

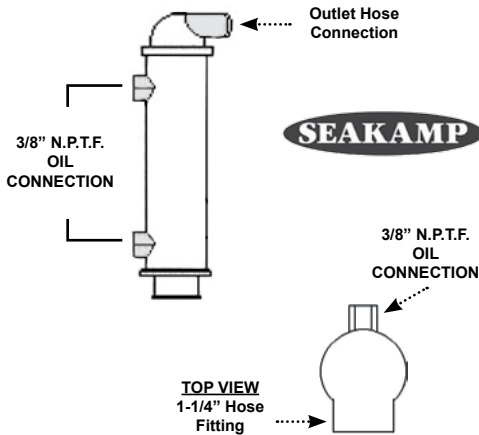

THIS UNIVERSAL OIL COOLER BRACKET CAN BE USED BY ITSELF OR IN COMBINATION WITH ANOTHER TO ATTACH OIL COOLERS TO MOST COMMON ATTACHING POINTS, (WORKS FOR IGNITION COILS)



Part#	Description
R090010	Universal Oil Cooler Bracket

Part#	Hose Conn.	Oil Conn. N.P.T.F.
SKP97743	1-1/4"	(2) 3/8"

SALT-AWAY[®]

Corrosion Control
SALT REMOVING TREATMENT

- Water-based, non-hazardous, non-toxic, & biodegradable
- Keeps metals from rusting & corroding with high-performing inhibitors
- Removes fresh salt & penetrates salt build up, immediate results
- Will not strip wax, leave spots or streaks, No rework or detailing surfaces



- SAWM - Mixing unit
- SAW16 - 16 Ounce spray bottle "Ready to use"
- SAW32 - 32 Ounce concentrate bottle
- SAW32M - 32 Ounce concentrate & Mixing unit combo
- SAW128 - 128 Ounce concentrate bottle

*55 GALLON DRUMS AVAILABLE UPON REQUEST

Without Salt-Away
after 1 year



With Salt-Away
after 1 year